

Frontseal®
 Rubber V-Rings for axial dynamic sealing



Description / Standard seal types	26
Installation and operation	27
Clamping bands & clips	29
Production and Quality assurance / Storage and handling	30
Standard sizes	31

Description

The Frontseal® is an all elastomer axial seal for rotary shafts and bearings. It rotates with the shaft and seals axially against a stationary counterface perpendicular to the shaft. This type of seal has been used widely for several applications and has proved to be reliable and effective against dust, dirt, water and oil splash and other media.

The ring consists of three parts:

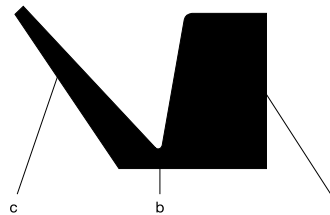

- a: the seal body, installed with interference to the shaft;
- b: the hinge, acting as a spring connection between the body and the lip;
- c: the conical and flexible sealing lip which provides the actual dynamic sealing against the counterface.

The counterface can be the side wall of the bearing, a washer or any housing.

Standard seal types

The Frontseal® is manufactured in different standard profiles:



VA

It's the most common profile. It has a perpendicular rear face. Wide range of sizes, from 3 to over 2000 [mm] shafts



VS

Wide body to ensure higher radial force than VA type. Range of sizes from 5 to 199 [mm] shafts



VL

This seal is intended for applications where available space is narrow. Range of sizes from 110 to over 1200 [mm] shafts



VLX

This seal is more compact than VL type, commonly used in confined spaces. Size list available on request



VE

It's a heavy-duty large diameter seal, used for instance in steel mills, paper mills and rolling mills as a dirt/water excluder seal. A clamping band can be used to improve axial fixation (see instruction IL03-02 and page 29). Range of sizes from 300 to over 2000 [mm] shafts



VRME

This heavy-duty profile is also primarily designed for protecting high speed bearing arrangements in rolling mills, papermaking and large machine applications. A clamping band can be used to improve axial fixation. Size list available on request



VAX

Heavy-duty Frontseal®, primarily designed for large high speed bearing arrangements, used for instance in rolling mills and papermaking machine applications. Additionally it can be used as secondary seal for heavy-duty applications where the primary seal has to be protected against water and/or particular contamination. Range of sizes from 200 to over 2000 [mm] shafts

Other types, modifications or larger diameters available upon request.

Installation and operation

Fitting

Fitting a Frontseal® is very simple. The ring must be slightly stretched and pushed along the shaft. It can either be done manually or with a simple tool, in a way that the distance to the counterface can be maintained constant over the circumference using little pressure. The lip of the Frontseal® should be lubricated with a thin film of grease or silicone oil. In case where friction must be reduced, coat the counterface with a low friction agent and do not apply grease to the lip. The shaft should be preferably dry and free from oil and grease.

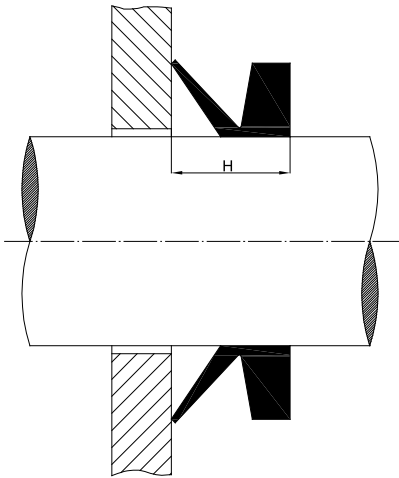

Frontseal® not preloaded

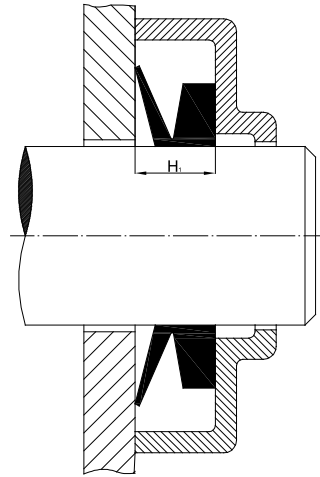

Frontseal® fitted with preloading using a tool

Eccentricity / Misalignment

The V-shape of the Frontseal® provides an effective and reliable sealing even with oval section, shaft run-out, eccentricity or shaft misalignment. Sealing is not even affected by a slightly tilted counterface (maximum permissible flatness deviation is usually defined as 0.4 [mm] per 100 [mm]).

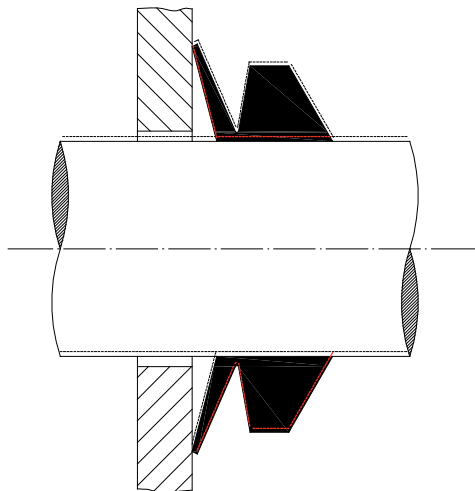

oval and/or eccentrically turning shaft

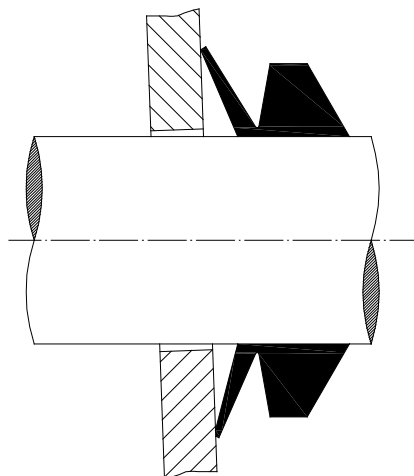

tilted counterface

Installation and operation

Counterface

The type of counterface finish is very important for an efficient sealing and for useful life of the seal. The surface must be smooth, free of scratches and sharp peaks. The choice of surface finish depends on the medium that has to be sealed and on the shaft speed. The choice of counterface materials is highly dependant on the medium too. For normal operating conditions, conventional mild steel of min 125 HB is sufficient. With an increase in speed and the presence of abrasive particles, the hardness of the counterface must also be increased. Surface treatment is suggested for water splashes or other corrosive media.

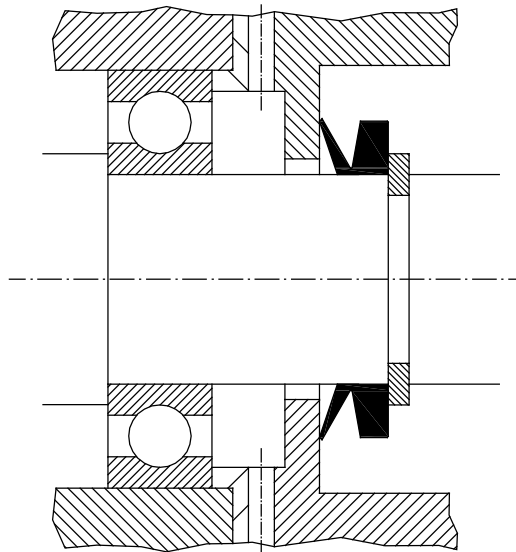

Peripheral speed

Due to the influence of the centrifugal force, the contact pressure of the lip decreases with increased speed.

At peripheral speed up to 8 [m/s] the lip of the Frontseal® has a good pressure against the counterface and it has the function of a light contact seal.

Over 8 [m/s] the seal must be axially supported and above 12 [m/s] radial retention is necessary, mounting the Frontseal® in an axial groove or applying an adequate support.

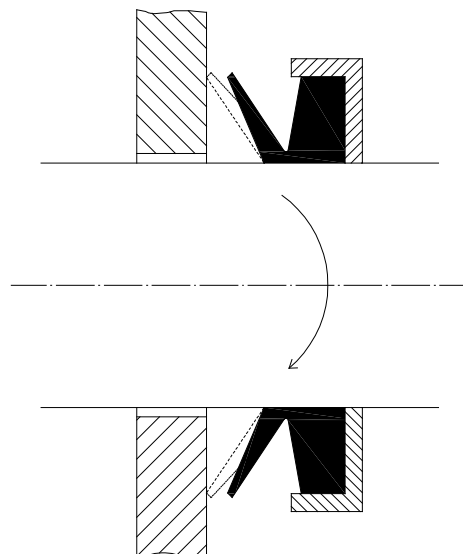

Clamping bands & clips for Frontseal® Type-VE in AISI430

When the Frontseal® is fitted on the shaft, the body of the ring is subject to a centrifugal force and can move from the shaft. For this reason the Frontseal® requires radial retention that can be supported by a clamping band.

Short description of technical features

The multi-range clamping bands are ideal for use in many different applications with a high mechanical load. With its tensile strength and the even tension force distribution it sets standards for reliable clamping. The clamping band perfectly fits on the VE Frontseal® and ensures an optimal tightness.

The clamping band has a width of 12 [mm] and a thickness of 0.8 [mm], perfectly fitting into the groove of DICHTA® Frontseal® Type VE which is 13 [mm] on all diameters. Both the clamping band and its clip are delivered in stainless steel AISI 430 (1.4016) material. Corrosion resistance in salt spray testing: min. 200 [h].

Clamping bands and supports for Frontseals® type VA are also available



Production and Quality assurance

Our Frontseal® is manufactured according to Quality Assurance Standards ISO 9001. All production phases are checked and all measurements are recorded and stored for tracing.

Our Frontseal® is individually inspected to ensure that sealing edge and sealing band are free from faults. Small cracks and shortcomings which could cause a split during installation or operation of the seal are also not accepted.

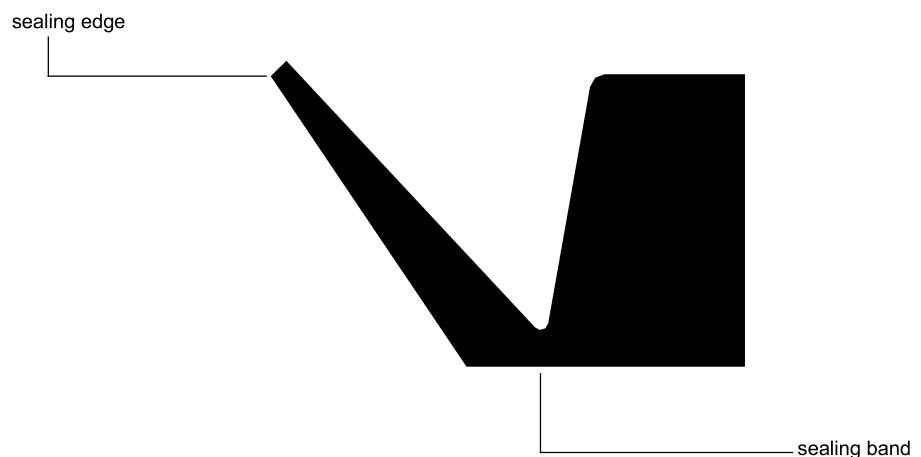

Storage and handling

Some storage precautions must be taken in order to avoid deterioration of the material. Frontseal® should be stored in a dust free and dry atmosphere and must be kept in its original packaging which should only be opened just before installation. Samples should be repacked after inspection.

Do not drop Frontseal® on shelves or boxes, nor hang seals on hooks, wires or nails, since in either case the seal can be damaged.

Seals should be stored on a first-in first-out basis to avoid ageing on the shelf. Avoid storage near sources of heat or near electrical equipment that may generate ozone. Also keep away from direct sunlight.

Avoid unnecessary pressure on the lip during storage.

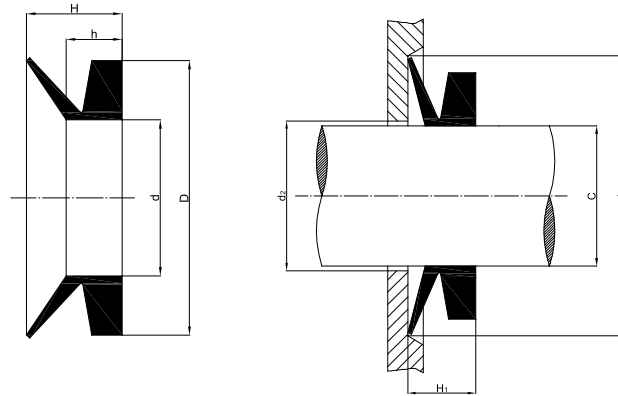
Standard sizes
Frontseal® VA

Ref.	Shaft diameter [mm]		Ring dimensions [mm]				Mounting dimensions [mm]		
	C		d	D	h	H	d ₂	d ₁	H ₁
VA 3	2,7	- 3,5	2,5	5,5	2,1	3	C + 1	C + 4	2,5 ± 0,3
VA 4	3,5	- 4,5	3,2	7,2	2,4	3,7	C + 1	C + 6	3 ± 0,4
VA 5	4,5	- 5,5	4	8	2,4	3,7	C + 1	C + 6	3 ± 0,4
VA 6	5,5	- 6,5	5	9	2,4	3,7	C + 1	C + 6	3 ± 0,4
VA 7	6,5	- 8	6	10	2,4	3,7	C + 1	C + 6	3 ± 0,4
VA 8	8	- 9,5	7	11	2,4	3,7	C + 1	C + 6	3 ± 0,4
VA 10	9,5	- 11,5	9	15	3,4	5,5	C + 2	C + 9	4,5 ± 0,6
VA 12	11,5	- 13,5	10,5	16,5	3,4	5,5	C + 2	C + 9	4,5 ± 0,6
VA 14	13,5	- 15,5	12,5	18,5	3,4	5,5	C + 2	C + 9	4,5 ± 0,6
VA 16	15,5	- 17,5	14	20	3,4	5,5	C + 2	C + 9	4,5 ± 0,6
VA 18	17,5	- 19	16	22	3,4	5,5	C + 2	C + 9	4,5 ± 0,6
VA 20	19	- 21	18	26	4,7	7,5	C + 2	C + 12	6 ± 0,8
VA 22	21	- 24	20	28	4,7	7,5	C + 2	C + 12	6 ± 0,8
VA 25	24	- 27	22	30	4,7	7,5	C + 2	C + 12	6 ± 0,8
VA 28	27	- 29	25	33	4,7	7,5	C + 3	C + 12	6 ± 0,8
VA 30	29	- 31	27	35	4,7	7,5	C + 3	C + 12	6 ± 0,8
VA 32	31	- 33	29	37	4,7	7,5	C + 3	C + 12	6 ± 0,8
VA 35	33	- 36	31	39	4,7	7,5	C + 3	C + 12	6 ± 0,8
VA 38	36	- 38	34	42	4,7	7,5	C + 3	C + 12	6 ± 0,8
VA 40	38	- 43	36	46	5,5	9	C + 3	C + 15	7 ± 1
VA 45	43	- 48	40	50	5,5	9	C + 3	C + 15	7 ± 1
VA 50	48	- 53	45	55	5,5	9	C + 3	C + 15	7 ± 1
VA 55	53	- 58	49	59	5,5	9	C + 3	C + 15	7 ± 1
VA 60	58	- 63	54	64	5,5	9	C + 3	C + 15	7 ± 1
VA 65	63	- 68	58	68	5,5	9	C + 3	C + 15	7 ± 1
VA 70	68	- 73	63	75	6,8	11	C + 4	C + 18	9 ± 1,2
VA 75	73	- 78	67	79	6,8	11	C + 4	C + 18	9 ± 1,2
VA 80	78	- 83	72	84	6,8	11	C + 4	C + 18	9 ± 1,2
VA 85	83	- 88	76	88	6,8	11	C + 4	C + 18	9 ± 1,2
VA 90	88	- 93	81	93	6,8	11	C + 4	C + 18	9 ± 1,2
VA 95	93	- 98	85	97	6,8	11	C + 4	C + 18	9 ± 1,2
VA 100	98	- 105	90	102	6,8	11	C + 4	C + 18	9 ± 1,2
VA 110	105	- 115	99	113	7,9	12,8	C + 4	C + 21	10,5 ± 1,5
VA 120	115	- 125	108	122	7,9	12,8	C + 4	C + 21	10,5 ± 1,5
VA 130	125	- 135	117	131	7,9	12,8	C + 4	C + 21	10,5 ± 1,5
VA 140	135	- 145	126	140	7,9	12,8	C + 4	C + 21	10,5 ± 1,5
VA 150	145	- 155	135	149	7,9	12,8	C + 4	C + 21	10,5 ± 1,5
VA 160	155	- 165	144	160	9	14,5	C + 5	C + 24	12 ± 1,8
VA 170	165	- 175	153	169	9	14,5	C + 5	C + 24	12 ± 1,8
VA 180	175	- 185	162	178	9	14,5	C + 5	C + 24	12 ± 1,8
VA 190	185	- 195	171	187	9	14,5	C + 5	C + 24	12 ± 1,8
VA 199	195	- 210	180	196	9	14,5	C + 5	C + 24	12 ± 1,8

Standard sizes

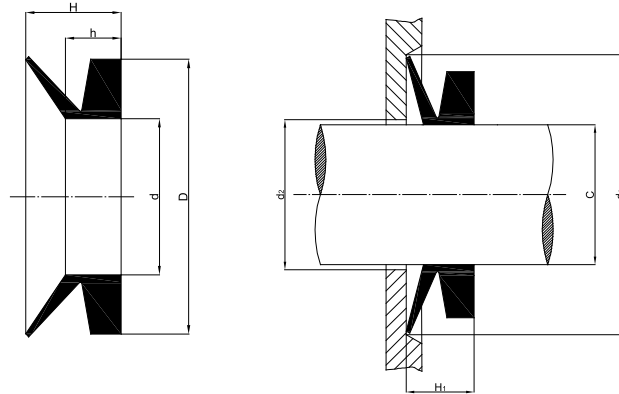

Frontseal® VA

Ref.	Shaft diameter [mm]		Ring dimensions [mm]				Mounting dimensions [mm]		
	C		d	D	h	H	d ₂	d ₁	H ₁
VA 200	190	- 210	180	210	14,3	25	C + 10	C + 45	20 ± 4
VA 220	210	- 235	198	228	14,3	25	C + 10	C + 45	20 ± 4
VA 250	235	- 265	225	255	14,3	25	C + 10	C + 45	20 ± 4
VA 275	265	- 290	247	277	14,3	25	C + 10	C + 45	20 ± 4
VA 300	290	- 310	270	300	14,3	25	C + 10	C + 45	20 ± 4
VA 325	310	- 335	292	322	14,3	25	C + 10	C + 45	20 ± 4
VA 350	335	- 365	315	345	14,3	25	C + 10	C + 45	20 ± 4
VA 375	365	- 390	337	367	14,3	25	C + 10	C + 45	20 ± 4
VA 400	390	- 430	360	390	14,3	25	C + 10	C + 45	20 ± 4
VA 450	430	- 480	405	435	14,3	25	C + 10	C + 45	20 ± 4
VA 500	480	- 530	450	480	14,3	25	C + 10	C + 45	20 ± 4
VA 550	530	- 580	495	525	14,3	25	C + 10	C + 45	20 ± 4
VA 600	580	- 630	540	570	14,3	25	C + 10	C + 45	20 ± 4
VA 650	630	- 665	600	630	14,3	25	C + 10	C + 45	20 ± 4
VA 700	665	- 705	630	660	14,3	25	C + 10	C + 45	20 ± 4
VA 725	705	- 745	670	700	14,3	25	C + 10	C + 45	20 ± 4
VA 750	745	- 785	705	735	14,3	25	C + 10	C + 45	20 ± 4
VA 800	785	- 830	745	775	14,3	25	C + 10	C + 45	20 ± 4
VA 850	830	- 875	785	815	14,3	25	C + 10	C + 45	20 ± 4
VA 900	875	- 920	825	855	14,3	25	C + 10	C + 45	20 ± 4
VA 950	920	- 965	865	895	14,3	25	C + 10	C + 45	20 ± 4
VA 1000	965	- 1015	910	940	14,3	25	C + 10	C + 45	20 ± 4
VA 1050	1015	- 1065	955	985	14,3	25	C + 10	C + 45	20 ± 4
VA 1100	1065	- 1115	1000	1030	14,3	25	C + 10	C + 45	20 ± 4
VA 1150	1115	- 1165	1045	1075	14,3	25	C + 10	C + 45	20 ± 4
VA 1200	1165	- 1215	1090	1120	14,3	25	C + 10	C + 45	20 ± 4
VA 1250	1215	- 1270	1135	1165	14,3	25	C + 10	C + 45	20 ± 4
VA 1300	1270	- 1320	1180	1210	14,3	25	C + 10	C + 45	20 ± 4
VA 1350	1320	- 1370	1225	1255	14,3	25	C + 10	C + 45	20 ± 4
VA 1400	1370	- 1420	1270	1300	14,3	25	C + 10	C + 45	20 ± 4
VA 1450	1420	- 1470	1315	1345	14,3	25	C + 10	C + 45	20 ± 4
VA 1500	1470	- 1520	1360	1390	14,3	25	C + 10	C + 45	20 ± 4
VA 1550	1520	- 1570	1405	1435	14,3	25	C + 10	C + 45	20 ± 4
VA 1600	1570	- 1620	1450	1480	14,3	25	C + 10	C + 45	20 ± 4
VA 1650	1620	- 1670	1495	1525	14,3	25	C + 10	C + 45	20 ± 4
VA 1700	1670	- 1720	1540	1570	14,3	25	C + 10	C + 45	20 ± 4
VA 1750	1720	- 1770	1585	1615	14,3	25	C + 10	C + 45	20 ± 4
VA 1800	1770	- 1820	1630	1660	14,3	25	C + 10	C + 45	20 ± 4
VA 1850	1820	- 1870	1675	1705	14,3	25	C + 10	C + 45	20 ± 4
VA 1900	1870	- 1920	1720	1750	14,3	25	C + 10	C + 45	20 ± 4
VA 1950	1920	- 1970	1765	1795	14,3	25	C + 10	C + 45	20 ± 4
VA 2000	1970	- 2020	1810	1840	14,3	25	C + 10	C + 45	20 ± 4

Over 2000 [mm] available on request

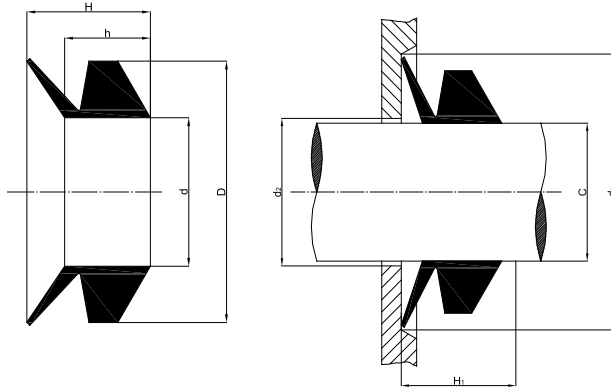
Standard sizes
Frontseal® VS

Ref.	Shaft diameter [mm]		Ring dimensions [mm]				Mounting dimensions [mm]		
	C		d	D	h	H	d ₂	d ₁	H ₁
VS 5	4,5 - 5,5		4	8	3,9	5,2	C + 1	C + 6	4,5 ± 0,4
VS 6	5,5 - 6,5		5	9	3,9	5,2	C + 1	C + 6	4,5 ± 0,4
VS 7	6,5 - 8		6	10	3,9	5,2	C + 1	C + 6	4,5 ± 0,4
VS 8	8 - 9,5		7	11	3,9	5,2	C + 1	C + 6	4,5 ± 0,4
VS 10	9,5 - 11,5		9	15	5,6	7,7	C + 2	C + 9	6,7 ± 0,6
VS 12	11,5 - 13,5		10,5	16,5	5,6	7,7	C + 2	C + 9	6,7 ± 0,6
VS 14	13,5 - 15,5		12,5	18,5	5,6	7,7	C + 2	C + 9	6,7 ± 0,6
VS 16	15,5 - 17,5		14	20	5,6	7,7	C + 2	C + 9	6,7 ± 0,6
VS 18	17,5 - 19		16	22	5,6	7,7	C + 2	C + 9	6,7 ± 0,6
VS 20	19 - 21		18	26	7,9	10,5	C + 2	C + 12	9 ± 0,8
VS 22	21 - 24		20	28	7,9	10,5	C + 2	C + 12	9 ± 0,8
VS 25	24 - 27		22	30	7,9	10,5	C + 2	C + 12	9 ± 0,8
VS 28	27 - 29		25	33	7,9	10,5	C + 3	C + 12	9 ± 0,8
VS 30	29 - 31		27	35	7,9	10,5	C + 3	C + 12	9 ± 0,8
VS 32	31 - 33		29	37	7,9	10,5	C + 3	C + 12	9 ± 0,8
VS 35	33 - 36		31	39	7,9	10,5	C + 3	C + 12	9 ± 0,8
VS 38	36 - 38		34	42	7,9	10,5	C + 3	C + 12	9 ± 0,8
VS 40	38 - 43		36	46	9,5	13	C + 3	C + 15	11 ± 1
VS 45	43 - 48		40	50	9,5	13	C + 3	C + 15	11 ± 1
VS 50	48 - 53		45	55	9,5	13	C + 3	C + 15	11 ± 1
VS 55	53 - 58		49	59	9,5	13	C + 3	C + 15	11 ± 1
VS 60	58 - 63		54	64	9,5	13	C + 3	C + 15	11 ± 1
VS 65	63 - 68		58	68	9,5	13	C + 3	C + 15	11 ± 1
VS 70	68 - 73		63	75	11,3	15,5	C + 4	C + 18	13,5 ± 1,2
VS 75	73 - 78		67	79	11,3	15,5	C + 4	C + 18	13,5 ± 1,2
VS 80	78 - 83		72	84	11,3	15,5	C + 4	C + 18	13,5 ± 1,2
VS 85	83 - 88		76	88	11,3	15,5	C + 4	C + 18	13,5 ± 1,2
VS 90	88 - 93		81	93	11,3	15,5	C + 4	C + 18	13,5 ± 1,2
VS 95	93 - 98		85	97	11,3	15,5	C + 4	C + 18	13,5 ± 1,2
VS 100	98 - 105		90	102	11,3	15,5	C + 4	C + 18	13,5 ± 1,2
VS 110	105 - 115		99	113	13,1	18	C + 4	C + 21	15,5 ± 1,5
VS 120	115 - 125		108	122	13,1	18	C + 4	C + 21	15,5 ± 1,5
VS 130	125 - 135		117	131	13,1	18	C + 4	C + 21	15,5 ± 1,5
VS 140	135 - 145		126	140	13,1	18	C + 4	C + 21	15,5 ± 1,5
VS 150	145 - 155		135	149	13,1	18	C + 4	C + 21	15,5 ± 1,5
VS 160	155 - 165		144	160	15	20,5	C + 5	C + 24	18 ± 1,8
VS 170	165 - 175		153	169	15	20,5	C + 5	C + 24	18 ± 1,8
VS 180	175 - 185		162	178	15	20,5	C + 5	C + 24	18 ± 1,8
VS 190	185 - 195		171	187	15	20,5	C + 5	C + 24	18 ± 1,8
VS 199	195 - 210		180	196	15	20,5	C + 5	C + 24	18 ± 1,8

Standard sizes

Frontseal® VL

Ring dimensions
 H = 10,5 [mm]
 h = 6,0 [mm]
 W = 6,5 [mm]

Assembling dimensions
 H1 = 8 +/- 1,5 [mm]
 d2 max = C + 5 [mm]
 d1 min = C + 20 [mm]

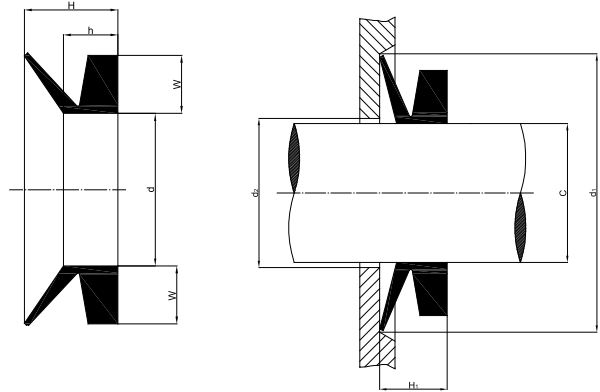

Reference	Shaft diameter [mm]	d [mm]
VL 110	105 - 115	99
VL 120	115 - 125	108
VL 130	125 - 135	117
VL 140	135 - 145	126
VL 150	145 - 155	135
VL 160	155 - 165	144
VL 170	165 - 175	153
VL 180	175 - 185	162
VL 190	185 - 195	171
VL 200	195 - 210	182
VL 220	210 - 233	198
VL 250	233 - 260	225
VL 275	260 - 285	247
VL 300	285 - 310	270
VL 325	310 - 335	292
VL 350	335 - 365	315
VL 375	365 - 385	337
VL 400	385 - 410	360
VL 425	410 - 440	382
VL 450	440 - 475	405
VL 500	475 - 510	450
VL 525	510 - 540	472
VL 550	540 - 565	495
VL 575	565 - 585	517
VL 600	585 - 625	540
VL 650	625 - 675	600
VL 700	675 - 710	630
VL 725	710 - 740	670
VL 750	740 - 775	705
VL 800	775 - 825	745
VL 850	825 - 875	785
VL 900	875 - 925	825
VL 950	925 - 975	865
VL 1000	975 - 1025	910
VL 1050	1025 - 1075	955
VL 1100	1075 - 1125	1000
VL 1150	1125 - 1175	1045
VL 1200	1175 - 1225	1090

Over 1200 [mm] available on request

Standard sizes
Frontseal® VE

Ring dimensions
 H = 65 [mm]
 h = 32 [mm]
 W = 30 [mm]

Assembling dimensions
 H1 = 50 +/- 12 [mm]
 d2 max = C + 24 [mm]
 d1 min = C + 115 [mm]

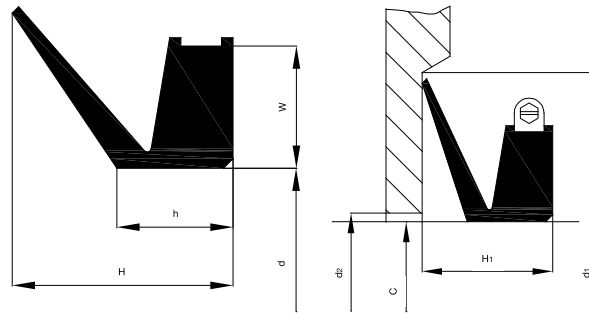

Reference	Shaft diameter [mm]	d [mm]
VE 300	300 - 305	294
VE 305	305 - 310	299
VE 310	310 - 315	304
VE 315	315 - 320	309
VE 320	320 - 325	314
VE 325	325 - 330	319
VE 330	330 - 335	323
VE 335	335 - 340	328
VE 340	340 - 345	333
VE 345	345 - 350	338
VE 350	350 - 355	343
VE 355	355 - 360	347
VE 360	360 - 365	352
VE 365	365 - 370	357
VE 370	370 - 375	362
VE 375	375 - 380	367
VE 380	380 - 385	371
VE 385	385 - 390	376
VE 390	390 - 395	381
VE 395	395 - 400	386
VE 400	400 - 405	391
VE 405	405 - 410	396
VE 410	410 - 415	401
VE 415	415 - 420	405
VE 420	420 - 425	410
VE 425	425 - 430	415
VE 430	430 - 435	420
VE 435	435 - 440	425
VE 440	440 - 445	429
VE 445	445 - 450	434
VE 450	450 - 455	439
VE 455	455 - 460	444
VE 460	460 - 465	448
VE 465	465 - 470	453
VE 470	470 - 475	458
VE 475	475 - 480	463
VE 480	480 - 485	468
VE 485	485 - 490	473
VE 490	490 - 495	478
VE 495	495 - 500	483
VE 500	500 - 505	488
VE 505	505 - 510	493
VE 510	510 - 515	497
VE 515	515 - 520	502
VE 520	520 - 525	507



Standard sizes

Frontseal® VE

Ring dimensions
 H = 65 [mm]
 h = 32 [mm]
 W = 30 [mm]

Assembling dimensions
 H1 = 50 +/- 12 [mm]
 d2 max = C + 24 [mm]
 d1 min = C + 115 [mm]

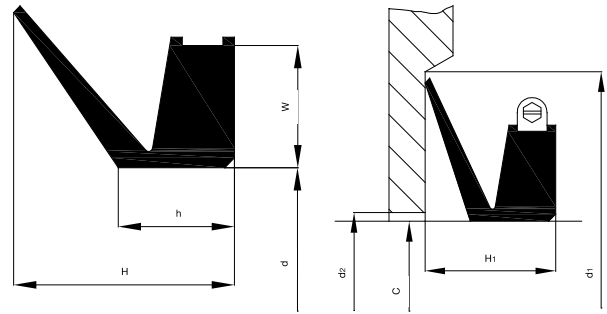

Reference	Shaft diameter [mm]	d [mm]
VE 525	525 - 530	512
VE 530	530 - 535	517
VE 535	535 - 540	521
VE 540	540 - 545	526
VE 545	545 - 550	531
VE 550	550 - 555	536
VE 555	555 - 560	541
VE 560	560 - 565	546
VE 565	565 - 570	550
VE 570	570 - 575	555
VE 575	575 - 580	560
VE 580	580 - 585	565
VE 585	585 - 590	570
VE 590	590 - 600	575
VE 600	600 - 610	582
VE 610	610 - 620	592
VE 620	620 - 630	602
VE 630	630 - 640	612
VE 640	640 - 650	621
VE 650	650 - 660	631
VE 660	660 - 670	640
VE 670	670 - 680	650
VE 680	680 - 690	660
VE 690	690 - 700	670
VE 700	700 - 710	680
VE 710	710 - 720	689
VE 720	720 - 730	699
VE 730	730 - 740	709
VE 740	740 - 750	718
VE 750	750 - 758	728
VE 760	758 - 766	735
VE 770	766 - 774	743
VE 780	774 - 783	751
VE 790	783 - 792	759
VE 800	792 - 801	768
VE 810	801 - 810	777
VE 820	810 - 821	786
VE 830	821 - 831	796
VE 840	831 - 841	805
VE 850	841 - 851	814
VE 860	851 - 861	824
VE 870	861 - 871	833
VE 880	871 - 882	843
VE 890	882 - 892	853
VE 900	892 - 912	871
VE 920	912 - 922	880
VE 930	922 - 933	890

Reference	Shaft diameter [mm]	d [mm]
VE 940	933 - 944	900
VE 950	944 - 955	911
VE 960	955 - 966	921
VE 970	966 - 977	932
VE 980	977 - 988	942
VE 990	988 - 999	953
VE 1000	999 - 1010	963
VE 1020	1010 - 1025	973
VE 1040	1025 - 1045	990
VE 1060	1045 - 1065	1008
VE 1080	1065 - 1085	1027
VE 1100	1085 - 1105	1045
VE 1120	1105 - 1125	1065
VE 1140	1125 - 1145	1084
VE 1160	1145 - 1165	1103
VE 1180	1165 - 1185	1121
VE 1200	1185 - 1205	1139
VE 1220	1205 - 1225	1157
VE 1240	1225 - 1245	1176
VE 1260	1245 - 1270	1195
VE 1280	1270 - 1295	1218
VE 1300	1295 - 1315	1240
VE 1325	1315 - 1340	1259
VE 1350	1340 - 1365	1281
VE 1375	1365 - 1390	1305
VE 1400	1390 - 1415	1328
VE 1425	1415 - 1440	1350
VE 1450	1440 - 1465	1374
VE 1475	1465 - 1490	1397
VE 1500	1490 - 1515	1419
VE 1525	1515 - 1540	1443
VE 1550	1540 - 1570	1467
VE 1575	1570 - 1600	1495
VE 1600	1600 - 1640	1524
VE 1650	1640 - 1680	1559
VE 1700	1680 - 1720	1596
VE 1750	1720 - 1765	1632
VE 1800	1765 - 1810	1671
VE 1850	1810 - 1855	1714
VE 1900	1855 - 1905	1753
VE 1950	1905 - 1955	1794
VE 2000	1955 - 2010	1844

Over 2000 [mm] available on request

Standard sizes
Frontseal® VAX

Ring dimensions Assembling dimensions
 H = 31 [mm] H1 = 25 +/- 5 [mm]
 h = 17,3 [mm] d2 max = C + 12 [mm]
 W = 17,8 [mm] d1 min = C + 50 [mm]

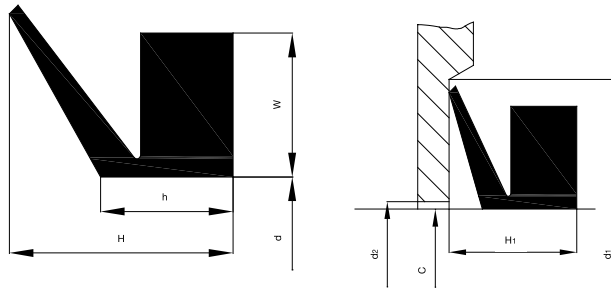

Reference	Shaft diameter [mm]	d [mm]
VAX 200	200 - 205	192
VAX 205	205 - 210	196
VAX 210	210 - 215	200
VAX 215	215 - 219	204
VAX 220	219 - 224	207
VAX 225	224 - 228	211
VAX 230	228 - 232	215
VAX 235	232 - 236	219
VAX 240	236 - 240	223
VAX 250	240 - 250	227
VAX 260	250 - 260	236
VAX 270	260 - 270	245
VAX 280	270 - 281	255
VAX 290	281 - 292	265
VAX 300	292 - 303	275
VAX 310	303 - 313	285
VAX 320	313 - 325	295
VAX 330	325 - 335	305
VAX 340	335 - 345	315
VAX 350	345 - 355	322
VAX 360	355 - 372	328
VAX 380	372 - 390	344
VAX 400	390 - 415	360
VAX 425	415 - 443	385
VAX 450	443 - 480	410
VAX 500	480 - 530	450
VAX 550	530 - 580	495
VAX 600	580 - 630	540
VAX 650	630 - 665	600
VAX 700	665 - 705	630

Reference	Shaft diameter [mm]	d [mm]
VAX 725	705 - 745	670
VAX 750	745 - 785	705
VAX 800	785 - 830	745
VAX 850	830 - 875	785
VAX 900	875 - 920	825
VAX 950	920 - 965	865
VAX 1000	965 - 1015	910
VAX 1050	1015 - 1065	955
VAX 1100	1065 - 1115	1000
VAX 1150	1115 - 1165	1045
VAX 1200	1165 - 1215	1090
VAX 1250	1215 - 1270	1135
VAX 1300	1270 - 1320	1180
VAX 1350	1320 - 1370	1225
VAX 1400	1370 - 1420	1270
VAX 1450	1420 - 1470	1315
VAX 1500	1470 - 1520	1360
VAX 1550	1520 - 1570	1405
VAX 1600	1570 - 1620	1450
VAX 1650	1620 - 1670	1495
VAX 1700	1670 - 1720	1540
VAX 1750	1720 - 1770	1585
VAX 1800	1770 - 1820	1630
VAX 1850	1820 - 1870	1675
VAX 1900	1870 - 1920	1720
VAX 1950	1920 - 1970	1765
VAX 2000	1970 - 2020	1810

Over 2000 [mm] available on request