



“SANDWICH” MOUNTS

Natural frequency : (1)
5 to 13 Hz

DESCRIPTION

The SANDWICH mount comprises one or more layers of elastomer bonded to flat, parallel metallic plates. These mountings may be cylindrical or rectangular. They are designed to withstand very high compressive loads. The range of mechanical characteristics is governed by the hardness of the rubber and the number of intermediate metallic plates.

These mountings can support compression from 20 to 100 bars.

The metal plates usually receive a phosphate anti-corrosion treatment.

The elastomer is polychloroprene which provides a high resistance to atmospheric exposure.

OPERATION

The design of the SANDWICH mount gives the following basic characteristics :

- Very slim,
- Large surface area,
- Stackable mountings,
- The suspended equipment is free to move in all directions,
- High ratio of axial stiffness to radial stiffness,
- Very high axial loads.

1) les fréquences propres indiquées, sont valables pour les charges maxi des plages d'utilisation citées dans le paragraphe : CARACTÉRISTIQUES TECHNIQUES.



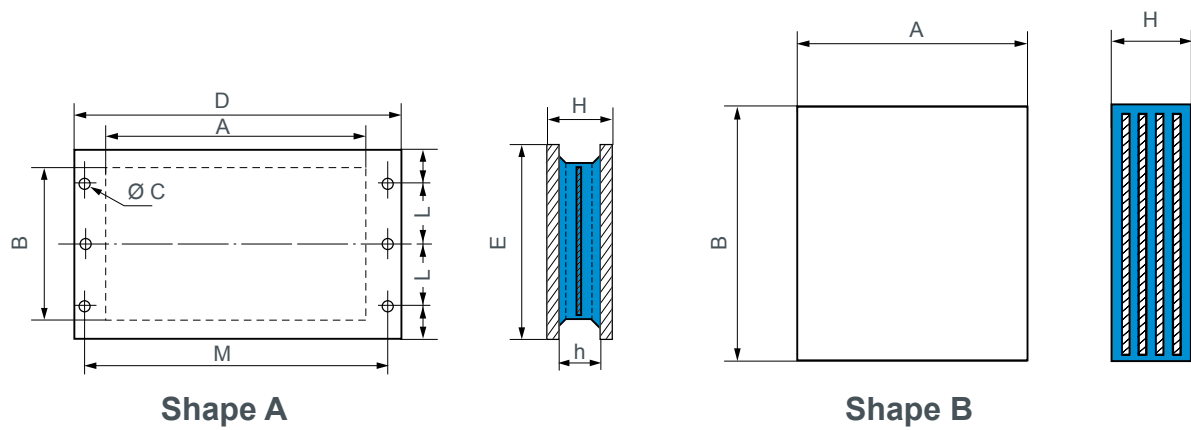

SUPPORTS AVEC FIXATIONS (ShapeA)

Ref. without intermediate plate	Ref. with intermediate plate	A (mm)	B (mm)	D (mm)	E (mm)	H (mm)	h (mm)	Nr holes x Ø C (mm)	L (mm)	M (mm)	Weight (kg)
539608	539607	182	142	255	170	49	40	6 x 9	58	235	5
539612	539933	372	252	460	300	61	50	6 x 13	100	430	18
539613	-	702	252	805	300	61	50	6 x 17	95	765	35
-	539267	160	110	230	110	58	44	4 x 15	35	202	5
539821	-	283	140	380	140	76	60	6 x 18	50	340	9,5

See current price list for availability of items.

Nominal static load (daN)	Deflection (mm)	Reference	Hardness
1000-4000	8	539821	50
1250-5000	4	539608	60
2500-10000	6	539607	45
6250-25000	3,5	539267	70
3750-15000	5	539607	60

Nominal static load (daN)	Deflection (mm)	Reference	Hardness
5000-20000	6	539612	45
7500-30000	7	539612	60
11250-45000	5	539613	60
15000-60000	4	539933	60

SUPPORTS SANS FIXATIONS (ShapeB)

Reference	A (=D) (mm)	B (=E) (mm)	H (mm)	Maximum static load (daN)
539832	200	165	38	95 000
539823	220	220	270	150 000
539833	240	200	38	145 000
539992	250	250	140	200 000
539820	400	300	78	380 000
539835	405	255	61	310 000
539537	500	500	66,5	870 000
539890	510	410	82	700 000
539939	600	500	125	1 000 000
539520	650	650	152	1 500 000
539924	702	252	50	450 000
539903	800	250	190	480 000
539701	750	750	300	2 000 000
519821	200	190	60	115 000
519822	260	230	60	185 000
519823	280	180	60	143 000



CYLINDRICAL MOUNTINGS

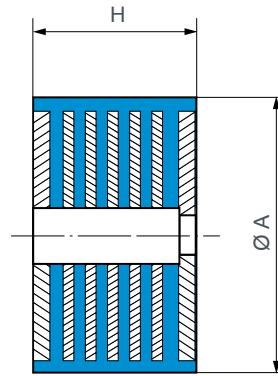
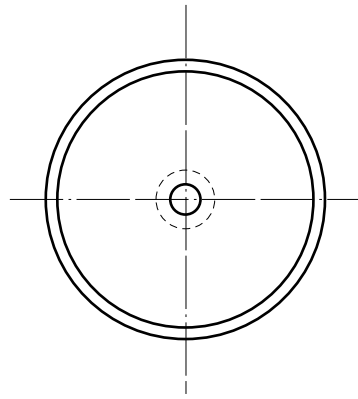

Dimensions can change. Please contact us.

Reference	Ø A (mm)	H (mm)	Nominal static load (daN)
539904	115	54	1 500
544051	150	110	12 000
539796	200	94,5	18 000
539983	200	90	5 000
539539	275	275	5 000
539938	320	19	100 000
539937	350	105	110 000
539900	400	117	150 000
544078	600	167	300 000
544079	600	285	433 000
544080	860	300	650 000

Various types of fixing are available. Consult us for information.

DOMINANTLY RADIAL MOUNTINGS

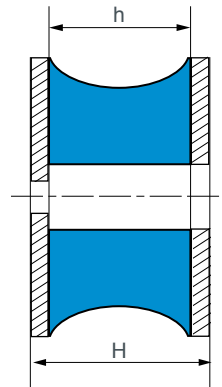
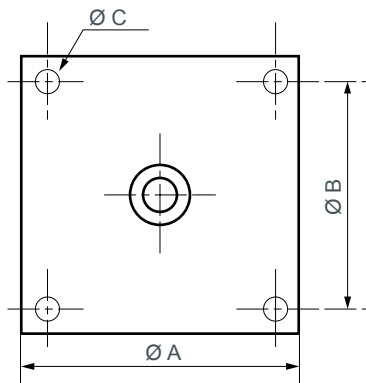

Dimensions can change. Please contact us.

Reference	A (mm)	h (mm)	B (mm)	H (mm)	Ø C (mm)	Shear		Compression (daN)
						(mm)	(daN)	
534646	150	62	120	70	12,5	20	200	1 500
534647	150	62	120	70	12,5	20	150	1 000
534455	232	74	190	86	16,5	25	500	2 000
534456	232	74	190	86	16,5	25	625	3 500
539898*	180	88	146	100	13	10	400	3 000
539917*	180	66	146	76	13	10	250	1 500
539940	300 x 480	318	430 x 219	350	18	70	4 500	13 000
539806	360 x 200	100	330 x 170	120	18	30	1 200	3 000
544051*	240 x 160	100	190 x 110	110	17	30	1 800	10 000

* Multilayer laminated part.

Various types of fixing are available. Please consult us for information.



HUTCHINSON®
PAULSTRA

PAULSTRA - 61 rue Marius AUFAN - 92309 Levallois-Perret Cedex - France - T. +33 1 40 89 53 31 - F. +33 1 47 25 28 96
www.paulstra-industry.com