

Mounting Feet

Type N
Type NOX

Accessory:
Base plate P

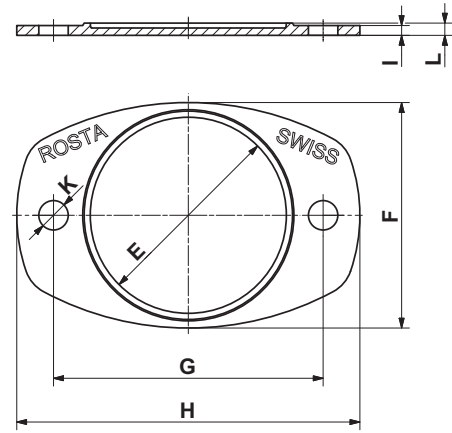
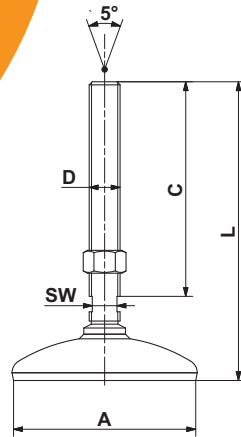

N and NOX

Art. No.	Type	Load Gmin. - Gmax. [N]	Natural frequency Gmin. - Gmax. [Hz]						Weight [kg]	Material structure (rubber pad NBR with 50 ShA)
				øA	C	D	L	SW		
05 058 001	N 80 M12	1'500 - 6'000	25 - 22	80	55	M12	100	10	0.3	zincd, cover blue painted
05 058 002	N 80 M16	5'000 - 12'000	22 - 19	80	136	M16	182	13	0.5	zincd, cover blue painted
05 058 102	NOX 80 M16									stainless steel 1.4301 and 1.4305
05 058 004	N 120 M20	10'000 - 20'000	22 - 19	120	139	M20	195	16	1.0	zincd, cover blue painted
05 058 103	NOX 120 M20									stainless steel 1.4301 and 1.4305

Base plate P

Art. No.	Type	Accessory to								Weight [kg]	Material structure
			øE	F	G	H	I	øK	L		
05 060 101	P 80	N / NOX 80	80	92	110	140	4	12	5	0.1	Light metal cast
05 060 102	P 120	N / NOX 120	120	135	170	210	5	16	7	0.3	

Options by high volume supplies

- other thread sizes and lengths
- higher load capacities
- other painting
- imprint of company logo

Applications

For the isolation of vibrations and solid-borne noise, also for machinery and apparatus requiring levelling, such as air conditioning plants, woodworking machinery, pumps, tanks, containers, transport systems, tooling machines, assembly lines and workshop equipment.

For further information to customized elements and installation examples as from page 3.14.

