

Martin
Leveling Components

Linea Antivibrante ***Anti-Vibration Line***



Antivibranti

Italy

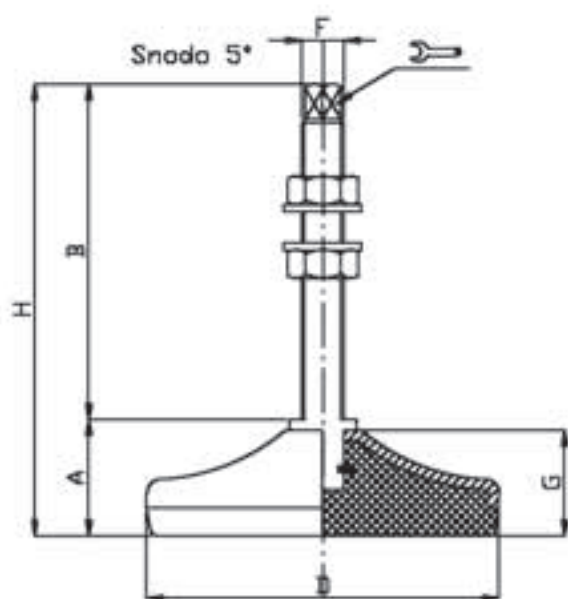

CODICE CODE	DIMENSIONI PRINCIPALI - MAIN DIMENSIONS							CARICO DINAMICO DYNAMIC LOAD NEWTON	CARICO STATICO STATIC LOAD NEWTON
	A	B	D		F	G	H		
28000Z	28	75	Ø 80	8	M12	25	103	2500	4500
28000I	28	75	Ø 80	8	M12	25	103	2500	4500
28020Z	28	100	Ø 80	9	M14	25	128	2500	4500
28020I	28	100	Ø 80	9	M14	25	128	2500	4500
28030Z	31	75	Ø 100	8	M12	28	106	5000	9000
28030I	31	75	Ø 100	8	M12	28	106	5000	9000
28040Z	31	125	Ø 100	9	M14	28	156	5000	9000
28040I	31	125	Ø 100	9	M14	28	156	5000	9000
28050Z	31	125	Ø 100	10	M16	28	156	5000	9000
28050I	31	125	Ø 100	10	M16	28	156	5000	9000
28060Z	35	125	Ø 120	10	M16	32	160	6000	11000
28060I	35	125	Ø 120	10	M16	32	160	6000	11000
28070Z	35	125	Ø 120	13	M20	32	160	6000	11000
28070I	35	125	Ø 120	13	M20	32	160	6000	11000
28080Z	35	125	Ø 120	16	M24	32	160	6000	11000
28080I	35	125	Ø 120	16	M24	32	160	6000	11000

Codice **Z** = acciaio zincato
Code **Z** = galvanized steel

Codice **I** = acciaio inossidabile
Code **I** = stainless steel

- Materiale base: acciaio inox (AISI304) / zincato C40. Gomma vulcanizzata NBR 80 shore
- I valori dei carichi sopra riportati sono calcolati in condizioni statiche alla metà della lunghezza dello stelo filettato. Qualora s'intendesse utilizzare i supporti in presenza di vibrazioni o carichi in movimento, tali valori dovranno essere adeguatamente ridotti. Per ulteriori chiarimenti consultare il nostro ufficio tecnico. Ogni nostra responsabilità decade in caso di manomissioni o modifiche dei componenti.
- *Material: stainless steel base 1.4301; galvanized steel C40. Pad: vulcanized rubber NBR 80 shore*
- *Load values above mentioned have to be considered referring to static conditions calculated at the half of the screw length. In conditions of vibrations or in presence of dynamic loads these values should be reduced. For further information consult our technical office. We cannot accept responsibility for mounts that have been tampered or modified*

BASE ANTIVIBRANTE CON STELO FISSO

ANTI VIBRATION BASE WITH FIXED SCREW

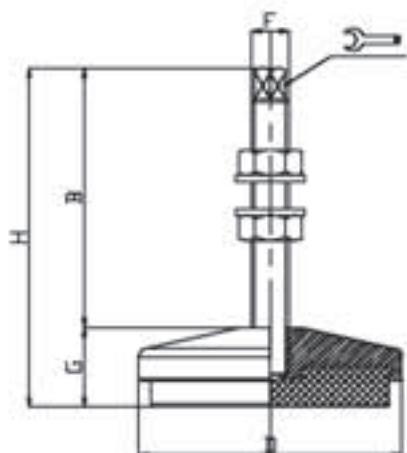

CODICE - CODE	DIMENSIONI PRINCIPALI - MAIN DIMENSIONS						CARICO DINAMICO DYNAMIC LOAD NEWTON	CARICO STATICO STATIC LOAD NEWTON
	B	D		F	G	H		
13180V	83	Ø 84	8	M12	30	113	3000	6000
13190V	121	Ø 104	9	M14	34	155	6000	11000
13200V	125	Ø 120	10	M16	37	162	7000	13000
13210V	128	Ø 140	10	M16	45	173	8000	16000
13220V	135	Ø 160	13	M20	45	180	12000	25000
13230V	135	Ø 180	13	M20	45	180	17000	35000
13232V	135	Ø 230	16	M24	55	190	25000	50000

Codice **V** = verniciato giallo

Code **V** = yellow painted

CODICE - CODE	DIMENSIONI PRINCIPALI - MAIN DIMENSIONS						CARICO DINAMICO DYNAMIC LOAD NEWTON	CARICO STATICO STATIC LOAD NEWTON
	B	D		F	G	H		
13240Z	83	Ø 84	8	M12	30	113	3000	6000
13250Z	121	Ø 104	9	M14	34	155	6000	11000
13260Z	125	Ø 120	10	M16	37	162	7000	13000
13270Z	128	Ø 140	10	M16	45	173	8000	16000
13280Z	135	Ø 160	13	M20	45	180	12000	25000
13290Z	135	Ø 180	13	M20	45	180	17000	35000
13292Z	135	Ø 230	16	M24	55	190	25000	50000

Codice **Z** = zincato

Code **Z** = galvanized steel

CODICE - CODE	DIMENSIONI PRINCIPALI - MAIN DIMENSIONS						CARICO DINAMICO DYNAMIC LOAD NEWTON	CARICO STATICO STATIC LOAD NEWTON
	B	D		F	G	H		
13300I	83	Ø 84	8	M12	30	113	3000	6000
13310I	121	Ø 104	9	M14	34	155	6000	11000
13320I	125	Ø 120	10	M16	37	162	7000	13000
13330I	128	Ø 140	10	M16	45	173	8000	16000
13340I	135	Ø 160	13	M20	45	180	12000	25000
13350I	135	Ø 180	13	M20	45	180	17000	35000

Codice **I** = inox

Code **I** = stainless steel

- Materiale base: acciaio verniciato, zincato e inox (AISI 304). Materiale stelo: acciaio zincato e inox (AISI 304). Gomma NBR 80 shore
- Applicazioni: macchine utensili, prese, cesoie, macchine tipografiche, macchine di stampaggio a iniezione. Il piede di livellamento viene già fornito completo di 2 dadi, 1 rondella piana e 1 rondella dentata
- Material: yellow painted/galvanized steel (C40) /stainless steel 1.4301base; galvanized / stainless steel screw 1.4301. Pad: rubber NBR 80 shore. The leveling is already provided with 2 nuts, 1 plain washer and 1 toothed washer.
- Application: machine tools; presses; injection molding machines; shearing machines. For higher loads, an anti-vibration pad 90 shore could be also supplied.

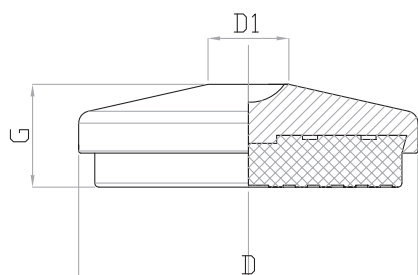

CODICE - CODE	DIMENSIONI PRINCIPALI - MAIN DIMENSIONS			CARICO DINAMICO DYNAMIC LOAD NEWTON	CARICO STATICO STATIC LOAD NEWTON
	D	G	D1		
13000V	Ø 84	30	17	3000	6000
13010V	Ø 104	34	19	6000	11000
13020V	Ø 120	37	21	7000	13000
13030V	Ø 140	45	22	8000	16000
13040V	Ø 160	45	22	12000	25000
13050V	Ø 180	45	24	17000	35000
13060V	Ø 230	55	32	25000	50000

Codice **V** = verniciato giallo Code **V** = yellow painted

CODICE - CODE	DIMENSIONI PRINCIPALI - MAIN DIMENSIONS			CARICO DINAMICO DYNAMIC LOAD NEWTON	CARICO STATICO STATIC LOAD NEWTON
	D	G	D1		
13060Z	Ø 84	30	17	3000	6000
13070Z	Ø 104	34	19	6000	11000
13080Z	Ø 120	37	21	7000	13000
13090Z	Ø 140	45	22	8000	16000
13100Z	Ø 160	45	22	12000	25000
13110Z	Ø 180	45	24	17000	35000
13120Z	Ø 230	55	32	25000	50000

Codice **Z** = zincato Code **Z** = galvanized

CODICE - CODE	DIMENSIONI PRINCIPALI - MAIN DIMENSIONS			CARICO DINAMICO DYNAMIC LOAD NEWTON	CARICO STATICO STATIC LOAD NEWTON
	D	G	D1		
13120I	Ø 84	30	17	3000	6000
13130I	Ø 104	34	19	6000	11000
13140I	Ø 120	37	21	7000	13000
13150I	Ø 140	45	22	8000	16000
13160I	Ø 160	45	22	12000	25000
13170I	Ø 180	45	24	17000	35000

Codice **I** = inox Code **I** = stainless steel

- Materiale base: acciaio verniciato, zincato e inox (AISI 304). Materiale stelo: acciaio zincato e inox(AISI 304). Gomma NBR 80 shore
- Applicazioni: macchine utensili, prese, cesoie, macchine tipografiche, macchine di stampaggio a iniezione.
- Material: yellow painted / galvanized/ stainless steel base 1.4301 with a niche as screw seat. Application: machine tools; presses; injection molding machines; shearing machines
- For higher loads, an anti-vibration pad 90 shore could be also supplied.

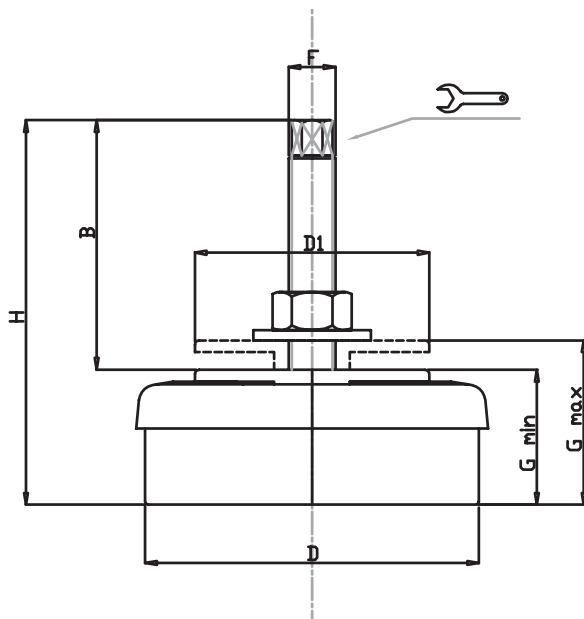



CODICE - CODE	DIMENSIONI PRINCIPALI - MAIN DIMENSIONS							CARICO DINAMICO DYNAMIC LOAD NEWTON	CARICO STATICO STATIC LOAD NEWTON
	B	D	D1		F	G	H		
14020	90	Ø 80	54	8	M12x1.25	40-50	130	2500	5000
14025	85	Ø 120	80	12	M16x1.5	45-58	130	4000	10000
14030	136	Ø 160	102	15	M20x1.5	54-68	190	9000	20000
14035	135	Ø 200	102	15	M20x1.5	60-75	195	15000	35000

Tecnopress è stato progettato per rendere la regolazione molto precisa e semplice. La stessa si ottiene agendo solo sull'estremità quadra dello stelo filettato e bloccando il controdado.

Tecnopress system guarantees a precise and easy regulation of the anti-vibration mount: one has only to act on the square end of the screw, blocking the jam-nut.

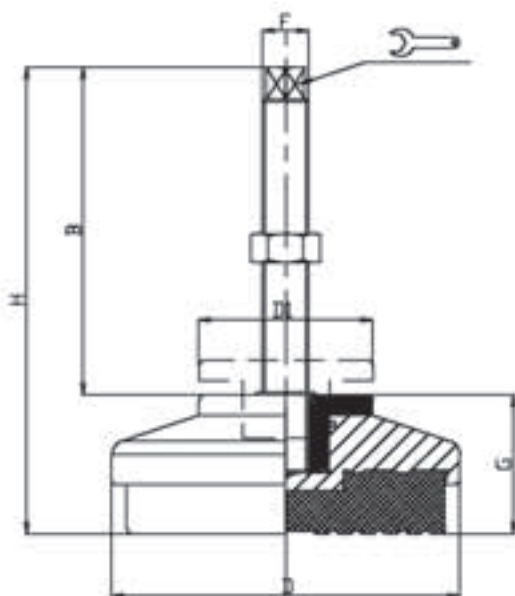
- Applicazioni: macchine utensili, prese, cesoie, macchine tipografiche, macchine di stampaggio a iniezione.
- Materiale base: FE zincato. Materiale stelo: acciaio zincato FE. Gomma antivibrante NBR 80 shore (per carichi maggiori, a richiesta gomma NBR 90 shore)
- Il piede di livellamento viene già fornito completo di 1 dado e 1 rondella piana.
- Application: machine tools; presses; injection molding machines; shearing machines
- Material: galvanized steel screw. Pad: rubber NBR 80 shore (for higher loads, an anti-vibration pad 90 shore could be also supplied.)
- The leveling is already provided with 1 nuts and 1 plain washer.



CODICE - CODE	DIMENSIONI PRINCIPALI - MAIN DIMENSIONS							CARICO DINAMICO DYNAMIC LOAD NEWTON	CARICO STATICO STATIC LOAD NEWTON
	B	D	D1		F	G MIN-MAX	H		
14050	110	Ø 104	Ø 60	9	M14	43-58	153	6000	11000
14060	110	Ø 123	Ø 60	10	M16	43-58	153	7000	13000
14070	110	Ø 140	Ø 80	10	M16	55-70	165	8000	16000
14080	110	Ø 160	Ø 80	13	M20	55-70	165	12000	25000
14090	110	Ø 180	Ø 80	13	M20	55-70	165	17000	35000

N.B. Disponibile anche con vite testa esagonale

Teknoplus è stato progettato per rendere la regolazione molto precisa e semplice. La stessa si ottiene agendo solo sull'estremità quadra dello stelo filettato e bloccando il controdado.

Teknoplus system guarantees a precise and easy regulation of the anti-vibration mount: one has only to act on the square end of the screw, blocking the jam-nut.

- Applicazioni: macchine utensili, presse, cesoie, macchine tipografiche, macchine di stampaggio a iniezione.
- Materiale base: acciaio verniciato colore giallo. Materiale stelo: acciaio zincato FE. Gomma antivibrante NBR 75 shore (per carichi maggiori, a richiesta gomma NBR 90 shore)
- Il piede di livellamento viene già fornito completo di 2 dadi, 1 rondella piana e 1 rondella dentata
- *Application: machine tools; presses; injection molding machines; shearing machines*
- *Material: painted steel base; galvanized steel screw. Pad: rubber NBR 75 shore (for higher loads, an anti-vibration pad 90 shore could be also supplied.)*
- *The leveling is already provided with 2 nuts, 1 plain washer and 1 toothed washer*

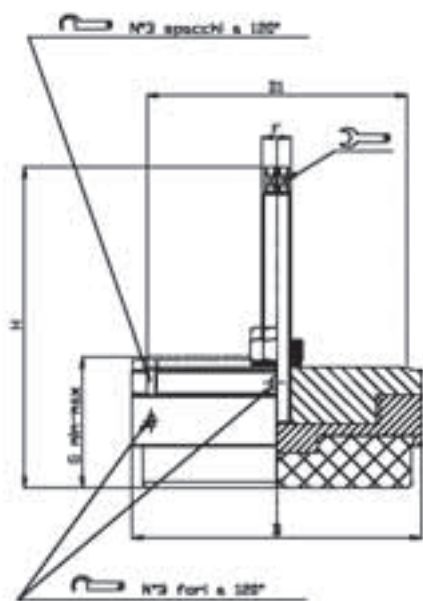

CODICE - CODE	DIMENSIONI PRINCIPALI - MAIN DIMENSIONS						CARICO DINAMICO DYNAMIC LOAD NEWTON	CARICO STATICO STATIC LOAD NEWTON
	D	D1	F		G	H		
14000	140	125	M12	8	60-66	110	9500	19500
14010	160	145	M16	10	60-66	133	14000	29000

Anti-moving è stato progettato per risolvere problemi di antistaticità dovuti ad accelerazioni trasversali che creano squilibrio nella distribuzione del peso nei punti di appoggio della macchina.

Modo d'uso: inserire il piattello tutto avvitato sotto il punto d'appoggio del basamento; avvitare dall'alto nel foro del basamento lo stelo filettato; per livellare la macchina agire sulla flangia superiore tramite i tre fori o spacchi

Anti moving has been designed to solve the problems of a tangential acceleration which may cause unbalance in the distribution of the weight on the bearing points of the machine.

Method of use: put the base with the flange completely screwed under the machine bed; from above screw the threaded stem in the hole of the machine bed; to level the machine act on the upper flange through the 3 holes or in the machined sapce.

- Materiale. Struttura in acciaio zincato C40. Gomma a sezione Nbr 90 shore nera
- Material: galvanized steel base C40. Pad: rubber NBR 90 shore



Ø 83 PORTATA 5000 N
Ø 83 LOAD CAPACITY 5000 N



Ø 103 PORTATA 10000 N
Ø 103 LOAD CAPACITY 10000 N



Ø 123 PORTATA 12000 N
Ø 123 LOAD CAPACITY 12000 N

**Tecnoeasy nasce per eliminare i problemi di vibrazioni
dove non ci siano esigenze di carichi pesanti**

**Applicazione: compressori, alimentatori, vibratori, autodistributori, macchine per
pulitura ecc.**

***Tecnoeasy is the right solution in contexts of light medium loads
Applications: compressors, feeders, vibrators, cleaning machines a.s.o.***

per ordinare è sufficiente aggiungere "/1" al codice standard.

Esempio: base plastica Ø 83, stelo In ferro zincato m20x200

codice standard... 10318 - codice Tecnoeasy... 10318/1

to make your order you just have to add a /1 to the standard CODE.

Example: Standard leveling 10318: plastic base d.83 screw M20x200

Tecnoeasy CODE: 10318/1

- Materiale base: poliammide rinforzata con fibre di vetro. Gomma NBR 70 shore
- Plastic base reinforced by fiber glass; anti-vibration pad NBR 70 shore

MODELLO	D m/m	H m/m	FILETTO (G)	FLESSIONE m/m	CARICO Kg.
T10-10	10	10	M4X10	2	10
T10-15	10	15	M4X10	3	8
T12,5-10	13	10	M5X12	1,5	12
T12,5-15	13	15	M5X12	3	10
T12,5-20	13	20	M5X12	3,5	8
T16-8	16	8	M4X10 o M5X12	1,5	15
T16-10	16	10	M4X10 o M5X12	1,5	20
T16-15	16	15	M4X10 o M5X12	3	20
T16-20	16	20	M4X10 o M5X12	4	20
T16-25	16	25	M4X10 o M5X12	5	15
T20-10	20	10	M6X13	2	30
T20-15	20	15	M6X13	3	25
T20-20	20	20	M6X18	4	25
T20-25	20	25	M6X18	5	25
T20-30	20	30	M6X18	7	25
T25-10	25	10	M8X20 o M6X16	1,5	50
T25-15	25	15	M8X20 o M6X16	3	50
T25-20	25	20	M8X20 o M6X16	4	50
T25-22	25	22	M8X20 o M6X16	4	45
T25-25	25	25	M8X20 o M6X16	5	40
T25-30	25	30	M8X20 o M6X16	6	35
T25-40	25	40	M8X20 o M6X16	10	50
T30-10	30	10	M8X20	2	90
T30-15	30	15	M8X20	3	90
T30-20	30	20	M8X20	4	90
T30-22	30	22	M8X20	4	90
T30-25	30	25	M8X20	5	85
T30-30	30	30	M8X20	6	80
T30-40	30	40	M8X20	8	60
T35-35	35	35	M8X20	8	90
T40-20	40	20	M10X25 o M8X20	4	160
T40-25	40	25	M10X25 o M8X20	6	155
T40-28	40	28	M10X25 o M8X20	6	155
T40-30	40	30	M10X25 o M8X20	8	150
T40-35	40	35	M10X25 o M8X20	8	120
T40-40	40	40	M10X25 o M8X20	10	120
T40-45	40	45	M10X25 o M8X20	12	110
T50-20	50	20	M10X25	4	250
T50-25	50	25	M10X25	5,5	250
T50-30	50	30	M10X25	8	250
T50-35	50	35	M10X25	9	230
T50-40	50	40	M10X25	10	220
T50-45	50	45	M10X25	11	210
T50-50	50	50	M10X25	12	200
T50-55	50	55	M10X25	13	200
T60-25	60	25	M10X30	5	400
T60-35	60	35	M10X30	7	350
T60-45	60	45	M10X30	10	300
T60-60	60	60	M10X30	12	250
T70-35	70	35	M10X30	7	450
T70-50	70	50	M10X30	10	350
T70-70	70	70	M10X30	13	300
T75-25	75	25	M12X35	5	650
T75-40	75	40	M12X35	9	500
T75-45	75	45	M12X35	10	500
T75-55	75	55	M12X35	13	450
T80-30	80	30	M14X35	5,5	900
T80-40	80	40	M14X35	9	600
T80-50	80	50	M14X35	10	750
T80-70	80	70	M14X35	15	550
T95-40	95	40	M16X45	8	1.200
T95-55	95	55	M16X45	11	1.000
T95-60	95	60	M16X45	12	800
T95-75	95	75	M16X45	13	700
T100-40	100	40	M16X45	8	1.200
T100-60	100	60	M16X45	15	1.100
T100-75	100	75	M16X45	17	1.000
T120-50	120	50	M16X45	9	1.500
T120-75	120	75	M16X45	13	1.200
T120-100	120	100	M16X45	16	1.000
T130-40	130	40	M16X45	6	1.900
T130-50	130	50	M16X45	9	1.600
T130-75	130	75	M16X45	13	1.450
T130-100	130	100	M16X45	16	1.200
T150-50	150	50	M16X45 o M20X50	9	1.800
T150-60	150	60	M16X45 o M20X50	14	2.200
T150-75	150	75	M16X45 o M20X50	16	2.000
T150-100	150	100	M16X45 o M20X50	16	1.400
T150-120	150	120	M16X45 o M20X50	16	1.300
T150-140	150	140	M16X45 o M20X50	16	1.200

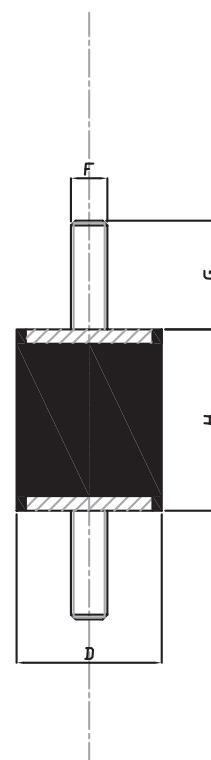

Antivibranti

MODELLO	D m/m	H m/m	FILETTO (F)	FLESSIONE m/m	CARICO Kg.
H10-10	10	10	M4	2	10
H10-15	10	15	M4	3	8
H12,5-15	13	15	M5	3	10
H12,5-20	13	20	M5	3,5	8
H16-15	16	15	M4 o M5	3	20
H16-20	16	20	M4 o M5	4	20
H16-25	16	25	M4 o M5	5	15
H20-15	20	15	M6	3	25
H20-20	20	20	M6	4	25
H20-25	20	25	M6	5	25
H20-30	20	30	M6	7	25
H25-15	25	15	M8 o M6	3	50
H25-20	25	20	M8 o M6	4	50
H25-22	25	22	M8 o M6	4	45
H25-25	25	25	M8 o M6	5	40
H25-30	25	30	M8 o M6	6	35
H25-40	25	40	M8 o M6	10	50
H30-15	30	15	M8	1,5	60
H30-20	30	20	M8	4	90
H30-22	30	22	M8	4	90
H30-25	30	25	M8	5	85
H30-30	30	30	M8	6	80
H30-40	30	40	M8	8	60
H35-35	35	35	M8	8	90
H40-20	40	20	M10 o M8	4	160
H40-25	40	25	M10 o M8	6	155
H40-28	40	28	M10 o M8	6	155
H40-30	40	30	M10 o M8	8	150
H40-35	40	35	M10 o M8	8	120
H40-40	40	40	M10 o M8	10	120
H40-45	40	45	M10 o M8	12	110
H50-20	50	20	M10	4	250
H50-25	50	25	M10	5,5	250
H50-30	50	30	M10	8	250
H50-35	50	35	M10	9	230
H50-40	50	40	M10	10	220
H50-45	50	45	M10	11	210
H50-50	50	50	M10	12	200
H50-55	50	55	M10	13	200
H60-25	60	25	M10	5	400
H60-35	60	35	M10	7	350
H60-45	60	45	M10	10	300
H60-60	60	60	M10	12	250
H70-35	70	35	M10	7	450
H70-50	70	50	M10	10	350
H70-70	70	70	M10	13	300
H75-25	75	25	M12	5	650
H75-40	75	40	M12	9	500
H75-45	75	45	M12	10	500
H75-55	75	55	M12	13	450
H80-30	80	30	M14	5,5	900
H80-40	80	40	M14	9	600
H80-50	80	50	M14	10	750
H80-70	80	70	M14	15	550
H95-40	95	40	M16	8	1.200
H95-55	95	55	M16	11	1.000
H95-60	95	60	M16	12	800
H95-75	95	75	M16	13	700
H100-40	100	40	M16	8	1.200
H100-60	100	60	M16	15	1.100
H100-75	100	75	M16	17	1.000
H120-50	120	50	M16	9	1.500
H120-75	120	75	M16	13	1.200
H120-100	120	100	M16	16	1.000
H130-40	130	40	M16	6	1.900
H130-50	130	50	M16	9	1.600
H130-75	130	75	M16	13	1.450
H130-100	130	100	M16	16	1.200
H150-50	150	50	M16 o M20	9	1.800
H150-60	150	60	M16 o M20	14	2.200
H150-75	150	75	M16 o M20	16	2.000
H150-100	150	100	M16 o M20	16	1.400
H150-120	150	120	M16 o M20	16	1.300
H150-140	150	140	M16 o M20	16	1.200

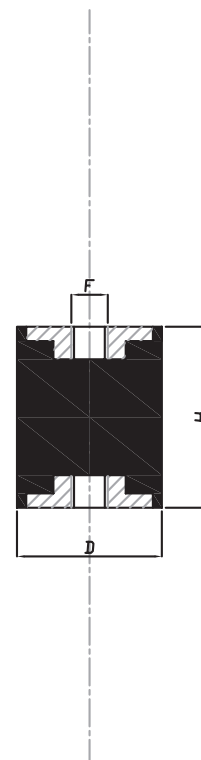

AMMORTIZZATORE CILINDRICO - SERIE TH

SILENT BLOCK – TH SERIES

MODELLO	D m/m	H m/m	FILETTO (G)	FLESSIONE m/m	CARICO Kg.
TH10-10	10	10	M4X10	2	10
TH10-15	10	15	M14X10	3	8
TH12,5-10	13	10	M5X12	1,5	12
TH12,5-15	13	15	M5X12	3	10
TH12,5-20	13	20	M5X12	3,5	8
TH16-8	16	8	M4X10 o M5X12	1,5	15
TH16-10	16	10	M4X10 o M5X12	1,5	20
TH16-15	16	15	M4X10 o M5X12	3	20
TH16-20	16	20	M4X10 o M5X12	4	20
TH16-25	16	25	M4X10 o M5X12	5	15
TH20-10	20	10	M6X16	2	30
TH20-15	20	15	M6X13	3	25
TH20-20	20	20	M6X18	4	25
TH20-25	20	25	M6X18	5	25
TH20-30	20	30	M6X18	7	25
TH25-10	25	10	M8X20 o M6X16	1,5	50
TH25-15	25	15	M8X20 o M6X16	3	50
TH25-20	25	20	M8X20 o M6X16	4	50
TH25-22	25	22	M8X20 o M6X16	4	45
TH25-25	25	25	M8X20 o M6X16	5	40
TH25-30	25	30	M8X20 o M6X16	6	35
TH25-40	25	40	M8X20 o M6X16	10	50
TH30-15	30	15	M8X20	3	90
TH30-20	30	20	M8X20	4	90
TH30-22	30	22	M8X20	4	90
TH30-25	30	25	M8X20	5	85
TH30-30	30	30	M8X20	6	80
TH30-40	30	40	M8X20	8	60
TH35-35	35	35	M8X20	8	90
TH40-20	40	20	M10X25 o M8X20	4	160
TH40-25	40	25	M10X25 o M8X20	6	155
TH40-28	40	28	M10X25 o M8X20	6	155
TH40-30	40	30	M10X25 o M8X20	8	150
TH40-35	40	35	M10X25 o M8X20	8	120
TH40-40	40	40	M10X25 o M8X20	10	120
TH40-45	40	45	M10X25 o M8X20	12	110
TH50-20	50	20	M10X25	4	250
TH50-25	50	25	M10X25	5,5	250
TH50-30	50	30	M10X25	8	250
TH50-35	50	35	M10X25	9	230
TH50-40	50	40	M10X25	10	220
TH50-45	50	45	M10X25	11	210
TH50-50	50	50	M10X25	12	200
TH50-55	50	55	M10X25	13	200
TH60-25	60	25	M10X30	5	400
TH60-35	60	35	M10X30	7	350
TH60-45	60	45	M10X30	10	300
TH60-60	60	60	M10X30	12	250
TH70-35	70	35	M10X30	7	450
TH70-50	70	50	M10X30	10	350
TH70-70	70	70	M10X30	13	300
TH75-25	75	25	M12X35	5	650
TH75-40	75	40	M12X35	9	500
TH75-45	75	45	M12X35	10	500
TH75-55	75	55	M12X35	13	450
TH80-30	80	30	M14X35	5,5	900
TH80-40	80	40	M14X35	9	600
TH80-50	80	50	M14X35	10	750
TH80-70	80	70	M14X35	15	550
TH95-40	95	40	M16X45	8	1.200
TH95-55	95	55	M16X45	11	1.000
TH95-60	95	60	M16X45	12	800
TH95-75	95	75	M16X45	13	700
TH100-40	100	40	M16X45	8	1.200
TH100-60	100	60	M16X45	15	1.100
TH100-75	100	75	M16X45	17	1.000
TH120-50	120	50	M16X45	6	1.500
TH120-75	120	75	M16X45	13	1.200
TH120-100	120	100	M16X45	16	1.000
TH130-40	130	40	M16X45	6	1.900
TH130-50	130	50	M16X45	9	1.600
TH130-75	130	75	M16X45	13	1.450
TH130-100	130	100	M16X45	16	1.200
TH150-50	150	50	M16X25 o M20X20	9	1.800
TH150-60	150	60	M16X25 o M20X20	14	2.200
TH150-75	150	75	M16X25 o M20X20	16	2.000
TH150-100	150	100	M16X25 o M20X20	16	1.400
TH150-120	150	120	M16X25 o M20X20	16	1.300
TH150-140	150	140	M16X25 o M20X20	16	1.200

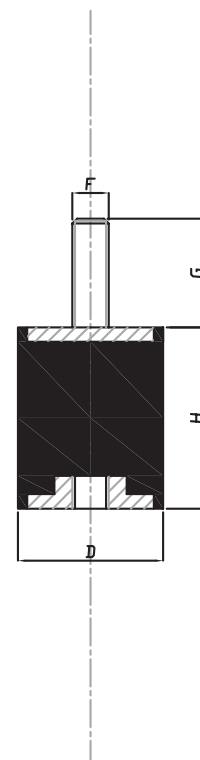

Antivibranti

MODELLO	D m/m	H m/m	FILETTO (G)	FLESSIONE m/m	CARICO Kg.
TS10-10	10	10	M4X10	2	10
TS10-15	10	15	M4X10	3	8
TS12,5-10	13	10	M5X12	1,5	12
TS12,5-15	13	15	M5X12	3	10
TS12,5-20	13	20	M5X12	3,5	8
TS16-8	16	8	M4X10 o M5X12	1,5	15
TS16-10	16	10	M4X10 o M5X12	1,5	20
TS16-15	16	15	M4X10 o M5X12	3	20
TS16-20	16	20	M4X10 o M5X12	4	20
TS16-25	16	25	M4X10 o M5X12	5	15
TS20-10	20	10	M6X13	2	30
TS20-15	20	15	M6X13	3	25
TS20-20	20	20	M6X18	4	25
TS20-25	20	25	M6X18	5	25
TS20-30	20	30	M6X18	7	25
TS25-10	25	10	M8X20 o M6X16	1,5	50
TS25-15	25	15	M8X20 o M6X16	3	50
TS25-20	25	20	M8X20 o M6X16	4	50
TS25-22	25	22	M8X20 o M6X16	4	45
TS25-25	25	25	M8X20 o M6X16	5	40
TS25-30	25	30	M8X20 o M6X16	6	35
TS25-40	25	40	M8X20 o M6X16	10	50
TS30-10	30	10	M8X20	2	90
TS30-15	30	15	M8X20	3	90
TS30-20	30	20	M8X20	4	90
TS30-22	30	22	M8X20	4	90
TS30-25	30	25	M8X20	5	85
TS30-30	30	30	M8X20	6	80
TS30-40	30	40	M8X20	8	60
TS35-35	35	35	M8X20	8	90
TS40-20	40	20	M10X25 o M8X20	4	160
TS40-25	40	25	M10X25 o M8X20	6	155
TS40-28	40	28	M10X25 o M8X20	6	155
TS40-30	40	30	M10X25 o M8X20	8	150
TS40-35	40	35	M10X25 o M8X20	8	120
TS40-40	40	40	M10X25 o M8X20	10	120
TS40-45	40	45	M10X25 o M8X20	12	110
TS50-20	50	20	M10X25	4	250
TS50-25	50	25	M10X25	5,5	250
TS50-30	50	30	M10X25	8	250
TS50-35	50	35	M10X25	9	230
TS50-40	50	40	M10X25	10	220
TS50-45	50	45	M10X25	11	210
TS50-50	50	50	M10X25	12	200
TS50-55	50	55	M10X25	13	200
TS60-25	60	25	M10X30	5	400
TS60-35	60	35	M10X30	7,7	350
TS60-45	60	45	M10X30	10	300
TS60-60	60	60	M10X30	12	250
TS70-35	70	35	M10X30	7	450
TS70-50	70	50	M10X30	10	350
TS70-70	70	70	M10X30	13	300
TS75-25	75	25	M12X35	5	650
TS75-40	75	40	M12X35	9	500
TS75-45	75	45	M12X35	10	500
TS75-55	75	55	M12X35	13	450
TS80-30	80	30	M14X35	5,5	900
TS80-40	80	40	M14X35	9	600
TS80-50	80	50	M14X35	10	750
TS80-70	80	70	M14X35	15	550
TS95-40	95	40	M16X45	8	1.200
TS95-55	95	55	M16X45	11	1.000
TS95-60	95	60	M16X45	12	800
TS95-75	95	75	M16X45	13	700
TS100-40	100	40	M16X45	8	1.200
TS100-60	100	60	M16X45	15	1.100
TS100-75	100	75	M16X45	17	1.000
TS120-50	120	50	M16X45	9	1.500
TS120-75	120	75	M16X45	13	1.200
TS120-100	120	100	M16X45	16	1.000
TS130-40	130	40	M16X45	6	1.900
TS130-50	130	50	M16X45	9	1.600
TS130-75	130	75	M16X45	13	1.450
TS130-100	130	100	M16X45	16	1.200
TS150-50	150	50	M16X25 o M20X20	9	1.800
TS150-60	150	60	M16X25 o M20X20	14	2.200
TS150-75	150	75	M16X25 o M20X20	16	2.000
TS150-100	150	100	M16X25 o M20X20	16	1.400
TS150-120	150	120	M16X25 o M20X20	16	1.300
TS150-140	150	140	M16X25 o M20X20	16	1.200

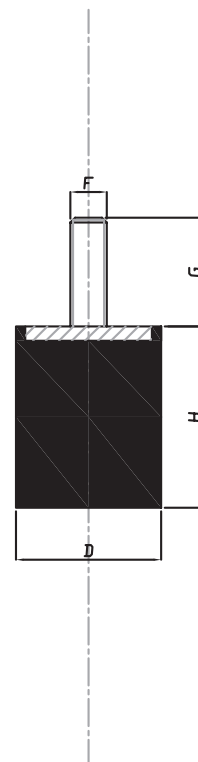

MODELLO	D m/m	H m/m	FILETTO (F)	FLESSIONE m/m	CARICO Kg.
HS10-10	10	10	M4	2	10
HS10-15	10	15	M4	3	8
HS12,5-10	13	10	M5	1,5	12
HS12,5-15	13	15	M5	3	10
HS12,5-20	13	20	M5	3,5	20
HS16-8	16	8	M4 o M5	1,5	15
HS16-10	16	10	M4 o M5	1,5	20
HS16-15	16	15	M4 o M5	3	20
HS16-20	16	20	M4 o M5	4	20
HS16-25	16	25	M4 o M5	5	15
HS20-10	20	10	M6	2	30
HS20-15	20	15	M6	3	25
HS20-20	20	20	M6	4	25
HS20-25	20	25	M6	5	25
HS20-30	20	30	M6	7	25
HS25-10	25	10	M8 o M6	1,5	50
HS25-15	25	15	M8 o M6	3	50
HS25-20	25	20	M8 o M6	4	50
HS25-22	25	22	M8 o M6	4	45
HS25-25	25	25	M8 o M6	5	40
HS25-30	25	30	M8 o M6	6	35
HS25-40	25	40	M8 o M6	10	50
HS30-10	30	10	M8	2	90
HS30-15	30	15	M8	3	90
HS30-20	30	20	M8	4	90
HS30-22	30	22	M8	4	90
HS30-25	30	25	M8	5	85
HS30-30	30	30	M8	6	80
HS30-40	30	40	M8	8	60
HS35-35	35	35	M8	8	90
HS40-20	40	20	M10 o M8	4	160
HS40-25	40	25	M10 o M8	6	155
HS40-28	40	28	M10 o M8	6	155
HS40-30	40	30	M10 o M8	8	150
HS40-35	40	35	M10 o M8	8	120
HS40-40	40	40	M10 o M8	10	120
HS40-45	40	45	M10 o M8	12	110
HS50-20	50	20	M10	4	250
HS50-25	50	25	M10	5,5	250
HS50-30	50	30	M10	8	250
HS50-35	50	35	M10	9	230
HS50-40	50	40	M10	10	220
HS50-45	50	45	M10	11	210
HS50-50	50	50	M10	12	200
HS50-55	50	55	M10	13	200
HS60-25	60	25	M10	5	400
HS60-35	60	35	M10	7	350
HS60-45	60	45	M10	10	300
HS60-60	60	60	M10	12	250
HS70-35	70	35	M10	7	450
HS70-50	70	50	M10	10	350
HS70-70	70	70	M10	13	300
HS75-25	75	25	M12	5	650
HS75-40	75	40	M12	9	500
HS75-45	75	45	M12	10	500
HS75-55	75	55	M12	13	450
HS80-30	80	30	M14	5,5	900
HS80-40	80	40	M14	9	600
HS80-50	80	50	M14	10	750
HS80-70	80	70	M14	15	550
HS95-40	95	40	M16	8	1.200
HS95-55	95	55	M16	11	01.00
HS95-60	95	60	M16	12	800
HS95-75	95	75	M16	13	700
HS100-40	100	40	M16	8	1.200
HS100-60	100	60	M16	15	1.100
HS100-75	100	75	M16	17	1.000
HS120-50	120	50	M16	9	1.500
HS120-75	120	75	M16	13	1.200
HS120-100	120	100	M16	16	1.000
HS130-40	130	40	M16	6	1.900
HS130-50	130	50	M16	9	1.600
HS130-75	130	75	M16	13	1.450
HS130-100	130	100	M16	16	1.200
HS150-40	150	40	M16 o M20	9	1.800
HS150-60	150	60	M16 o M20	14	2.200
HS150-75	150	75	M16 o M20	16	2.000
HS150-100	150	100	M16 o M20	16	1.400
HS150-120	150	120	M16 o M20	16	1.300
HS150-140	150	140	M16 o M20	16	1.200

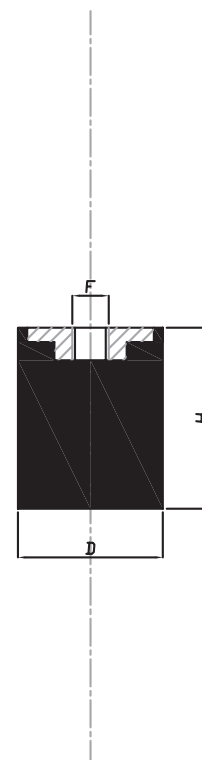

MODELLO	D m/m	H m/m	FILETTO (F)	G m/m	FLESSIONE m/m	CARICO Kg.
TX20-20	20	20	M6X18	18	4	25
TX20-25	20	25	M6X18	18	5	25
TX25-25	25	25	M8X18	18	5	40
TX25-30	25	30	M8X18	18	6	35
TX30-30	30	30	M8X18	18	6	80
TX30-40	30	40	M8X18	18	8	60
TX35-35	35	35	M8X18	18	8	90
TX40-30	40	30	M10X27	27	8	150
TX40-40	40	40	M10X27	27	10	120
TX50-30	50	30	M10X27	27	8	250
TX50-40	50	40	M10X27	27	10	220
TX50-50	50	50	M10X27	27	12	200
TX60-45	60	45	M10X27	27	10	300
TX60-60	60	60	M10X27	27	12	250

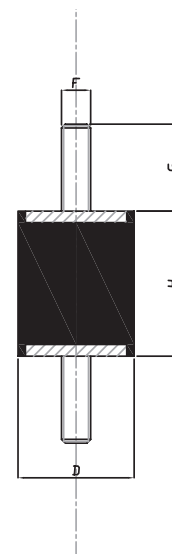

AMMORTIZZATORE CILINDRICO INOX - SERIE HDX
STAINLESS STEEL SILENT BLOCK - HDX SERIES

MODELLO	D m/m	H m/m	D1 m/m	FILETTO (F)	FLESSIONE m/m	CARICO Kg.
HDX60-36	60	36	37	M10	5	90
HDX60-60	60	60	51	M10	6	150
HDX70-56	70	56	50	M12	6	220
HDX90-77	90	77	79	M12	7	500
HDX108-85	108	85	95	M16	10	800
HDX130-96	130	96	115	M16	13	1.400

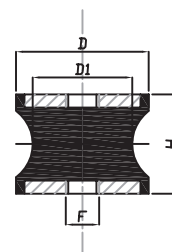

AMMORTIZZATORE DIABLO - SERIE TD

SILENT BLOCK - TD SERIES

MODELLO	D m/m	H m/m	D1 m/m	FILETTO (F)	G m/m	FLESSIONE m/m	CARICO Kg.
TD20-20	20	20	12	M6	18	18	15
TD30-25	30	25	24	M8	20	20	40
TD40-28	40	28	22	M10	25	25	50
TD57-44	57	44	25	M8	20	20	60
TD60-36	60	36	37	M10	30	30	90
TD60-43	60	46	35	M10	30	30	70
TD60-60	60	60	51	M10	30	30	150
TD70-56	70	56	50	M12	35	35	220
TD80-65	80	65	70	M14	35	35	400
TD90-77	90	77	79	M16	45	45	500
TD95-76	95	76	80	M16	45	45	400
TD108-85	108	85	95	M16	45	45	800
TD130-96	130	96	115	M16	45	45	1.400

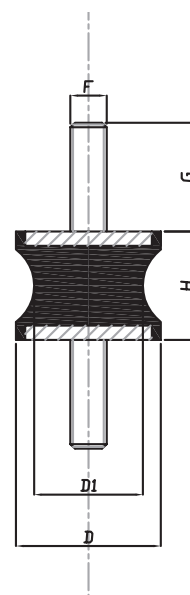

AMMORTIZZATORE DIABLO - SERIE HD

SILENT BLOCK HD SERIES

MODELLO	D m/m	H m/m	D1 m/m	FILETTO (F)	FLESSIONE m/m	CARICO Kg.
HD20-20	20	20	12	M6	2,5	15
HD30-25	30	25	24	M8	4	40
HD40-28	40	28	22	M10	5	60
HD60-36	60	36	37	M10	5	90
HD60-43	60	43	35	M10	4	70
HD60-60	60	60	51	M10	6	150
HD70-56	70	56	50	M12	6	220
HD80-65	80	65	70	M12	8	400
HD90-50	90	50	80	M12	4	800
HD95-76	95	76	80	M16	9,5	400
HD90-77	90	77	79	M12	7	500
HD108-85	108	85	95	M16	10	800
HD130-96	130	96	115	M16	13	1.400

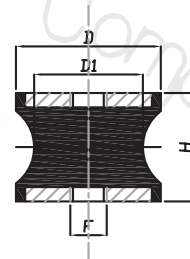

MODELLO	D m/m	H m/m	FILETTO (F)	G m/m	CARICO Kg.
TP-20	20	20	M6	18	70
TP-25	25	20	M8	20	100
TP-30	30	30	M6	17	150
TP-30	30	30	M8	20	150
TP-50	50	48	M10	25	380
TP-50X58	50	58	M8	20	400
TP-50X64	50	64	M8	35	370
TP-60	60	40	M14	62	550
TP-70	70	60	M12	35	550
TP-90	90	74	M16	45	1100
TP-95	95	82	M16	45	1100

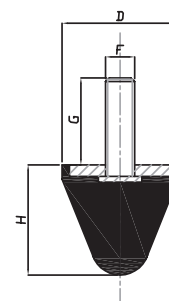

FINE CORSA PROGRESSIVI - FEMMINA
FEMALE

MODELLO	D m/m	H m/m	FILETTO (F)	CARICO Kg.
HP-20	20	20	M6	70
HP-25	25	20	M8	100
HP-30	30	30	M6	150
HP-30	30	30	M8	150
HP-50	50	48	M10	380
HP-70	70	60	M12	550
HP-90	90	74	M16	1100
HP-95	95	82	M16	1100

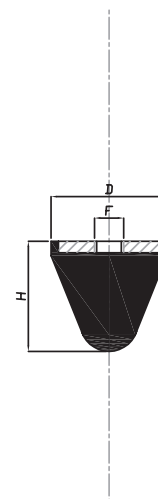

FINE CORSA PROGRESSIVI
SILENT BLOCKS

MODELLO	D m/m	H m/m	FILETTO (F)	G m/m	CARICO Kg.
TP-85	84	52	M12X35	35	1500
TP-120	120	75	M16X45	45	3000
TP-220	220	137	M24X80	80	15000
HP-85	84	52	M12	35	1500
HP-120	120	75	M16	45	3000

